

ENGLISH

STAR3 din STAR3 din ALM STAR3 din ALM HARMO



Energy & Harmonics Analyser

USER MANUAL

WARNING – Elcontrol Energy Net S.p.a. declines all liability for any damage to people or property caused by unsuitable or incorrect use of its products. Elcontrol Energy Net reserves the right to change product specifications without prior notice.

THREE PHASE (DELTA / STAR) CONNECTION, QUICK REFERENCE MEASURES PAGES

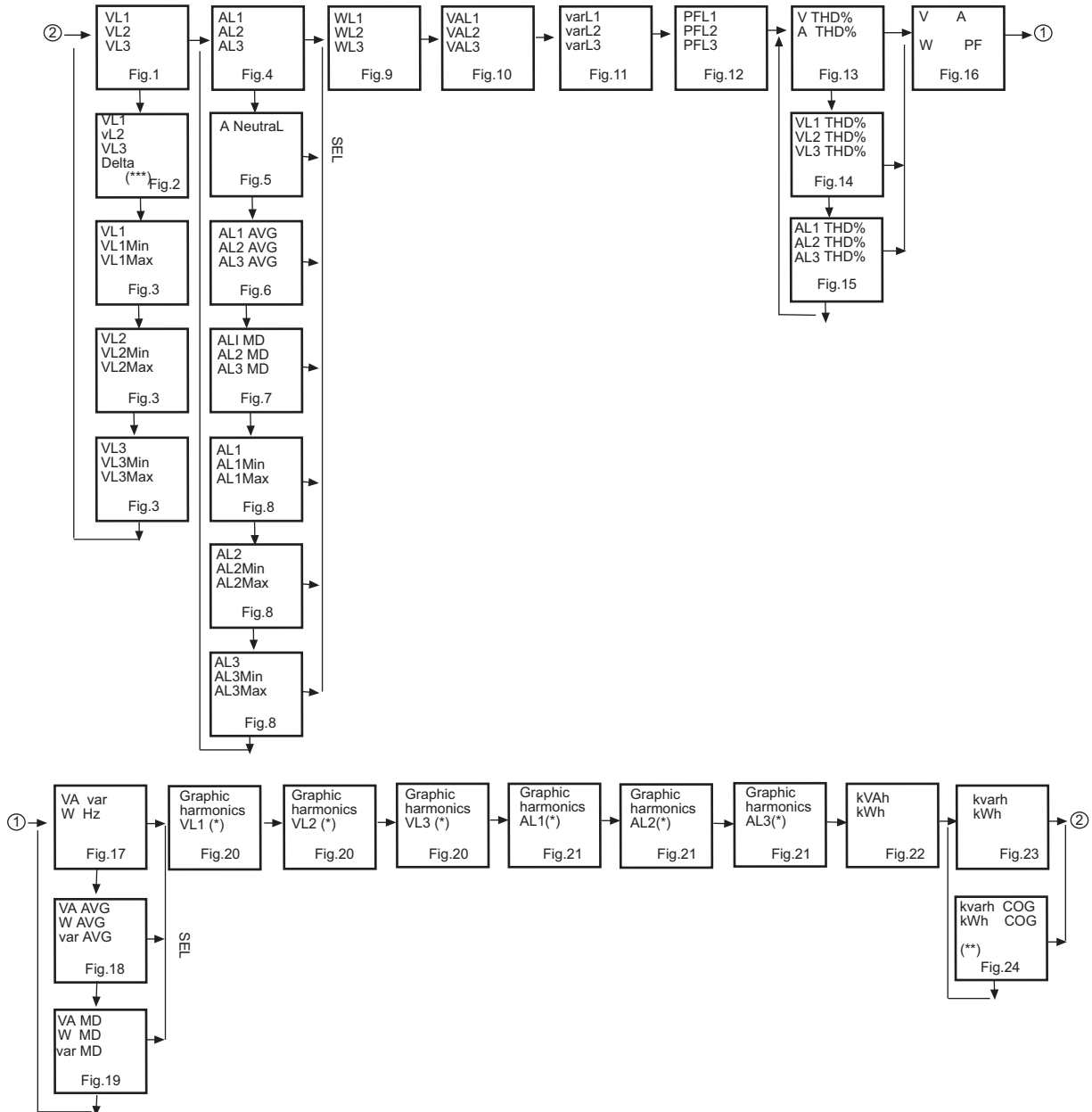

Note:

- (*) Only Harmo version
- (**) Only in cogeneration Mode
- (***) Only in Star connection

Legend:



DIPHASE CONNECTION QUICK REFERENCE MEASURES PAGES

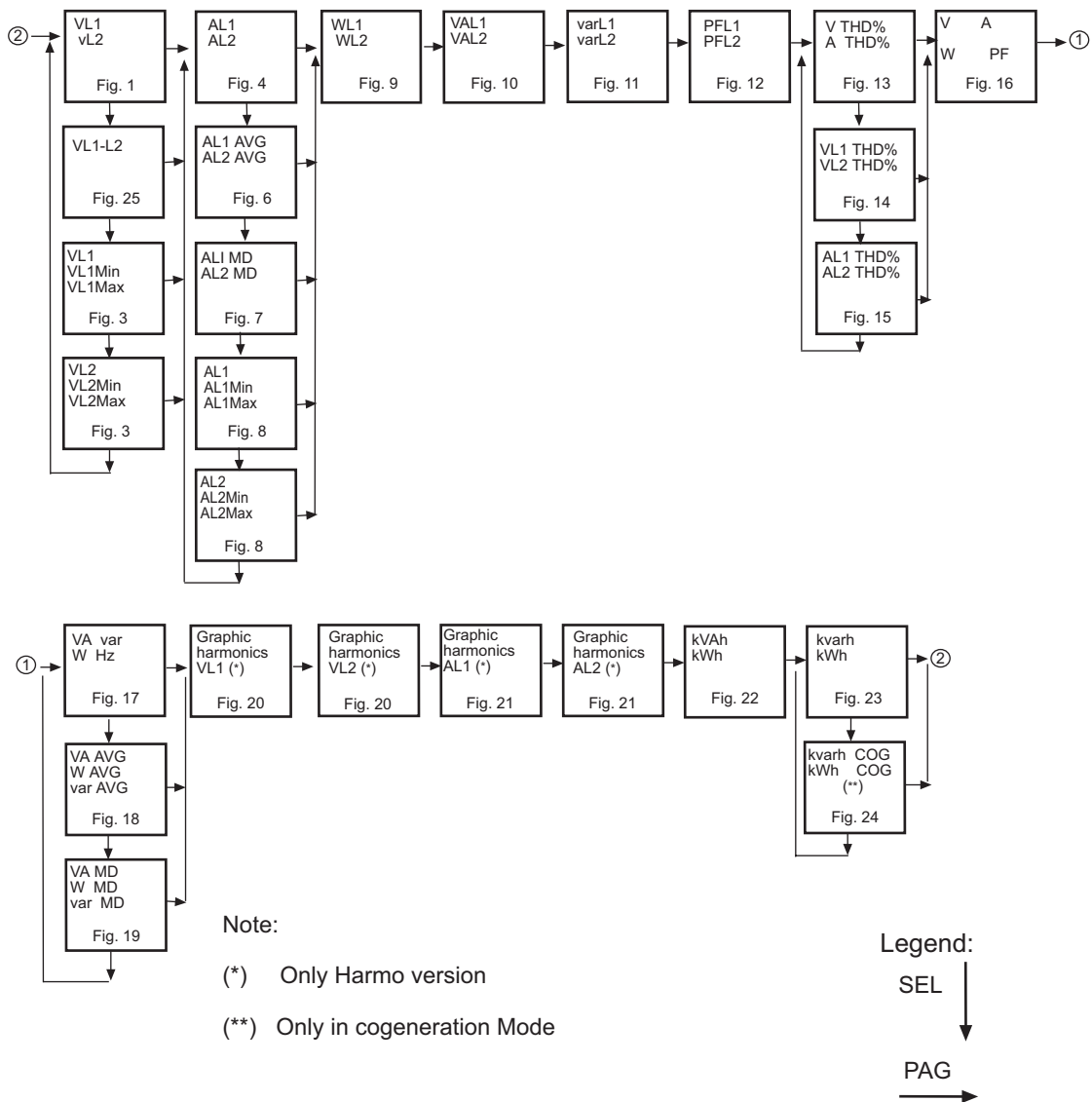

SINGLE-PHASE CONNECTION QUICK REFERENCE MEASURES PAGES

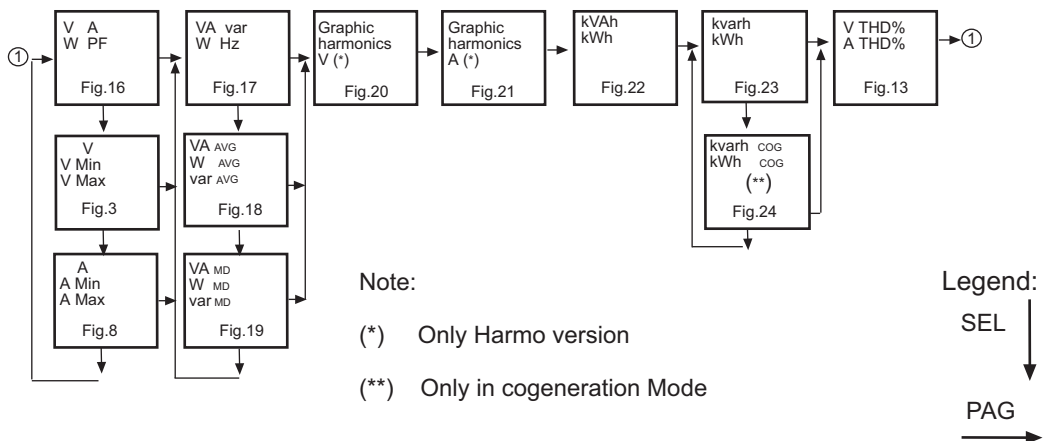

SETUP PAGES (ALL MODELS)

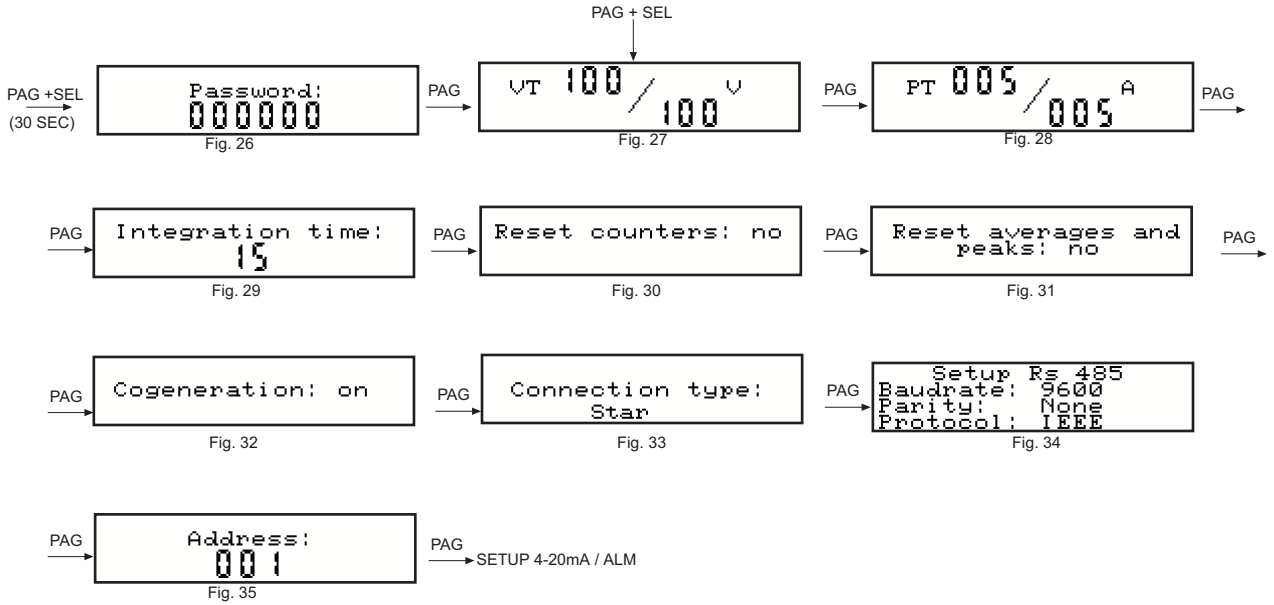

SETUP PAGES ALM VERSION

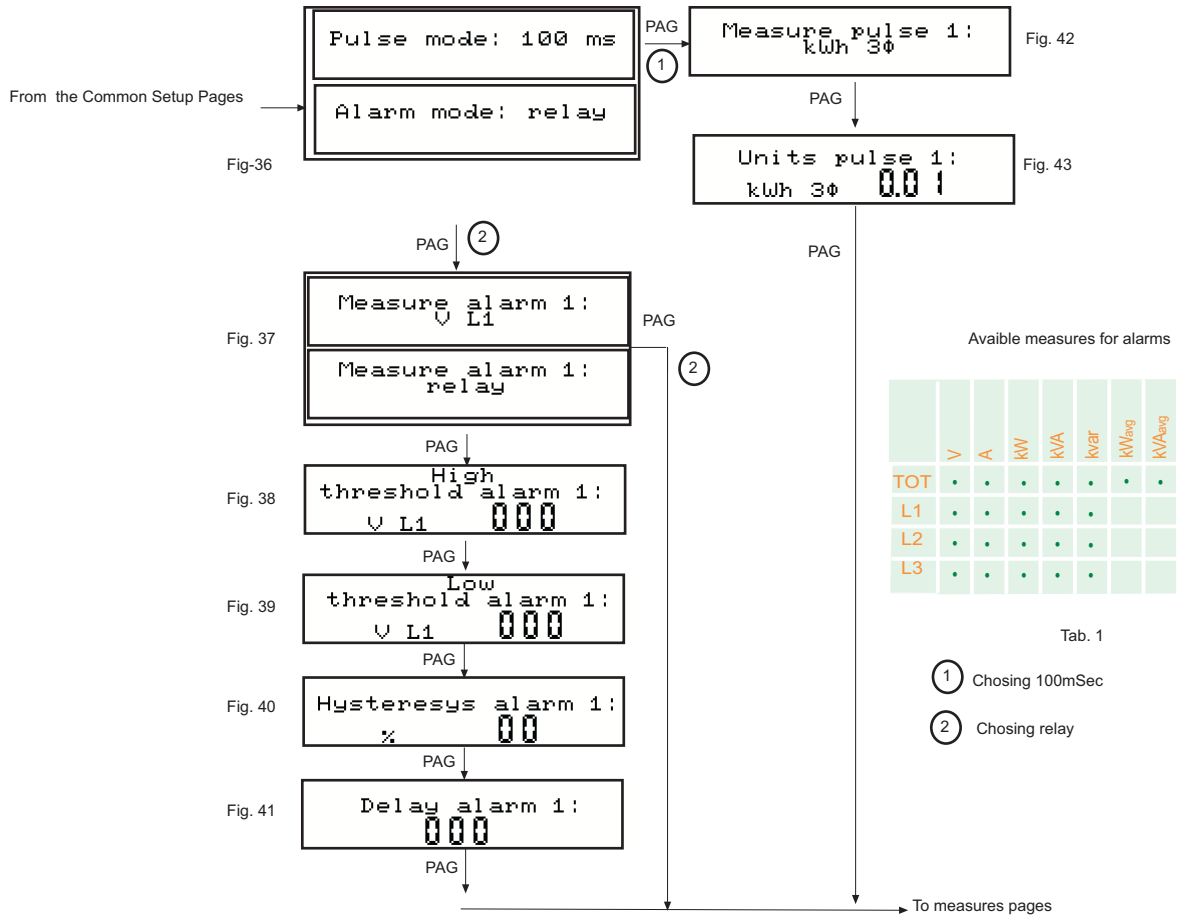

DISPLAYED MEASUREMENT

PARAMETERS	TOT	L1	L2	L3	N
Phase-neutral Voltage [V]	•	•	•	•	
Phase-phase Voltage [V]		L1-L2	L2-L3	L3-L1	
Minimum Voltage [V]		•	•	•	
Maximum Voltage [V]		•	•	•	
Current [A]	•	•	•	•	•
Power Factor	•	•	•	•	
Frequency [Hz]		•			
Average Current [A]		•	•	•	
Maximum Demand Current [I]		•	•	•	
Minimum Current [I]		•	•	•	
Maximum Current [I]		•	•	•	
Active Power [kW]	•	•	•	•	
Reactive Power [kvar]	•	•	•	•	
Apparent Power [kVA]	•	•	•	•	
Average Active Power [kW]	•				
Average Reactive Power [kvar]	•				
Average Apparent Power [kVA]	•				
Maximum Demand Active Power [kW]	•				
Maximum Demand Reactive Power [kvar]	•				
Maximum Demand Apparent Power [kVA]	•				
Positive (Imported) Active Energy [kWh]	•				
Cog-negative (Expo) Active Energy [kWh]	•				
Positive Reactive Energy [kvarh]	•				
Cog-negative Reactive Energy [kvarh]	•				
Apparent Energy [Kvah]	•				
Current Thd%	•	•	•	•	•
Voltage Thd%	•	•	•	•	•

HARMONIC ORDER (k=1..25 @ 50Hz - k=1..20 @ 60Hz)	L1	L2	L3
HARMONIC VOLTAGE VK	•	•	•
HARMONIC CURRENT IK	•	•	•

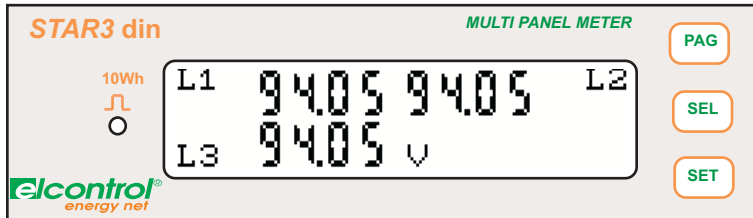

Fig.1



Fig.9

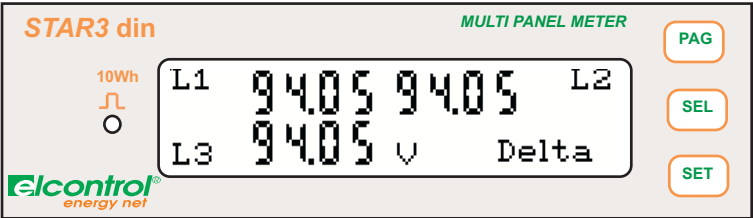

Fig.2

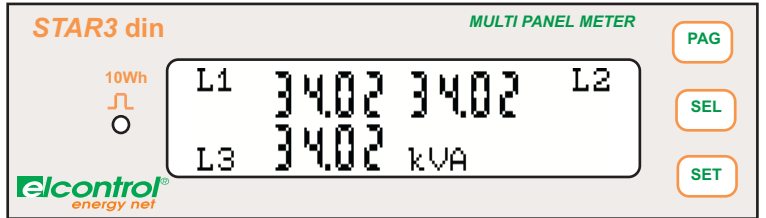

Fig.10

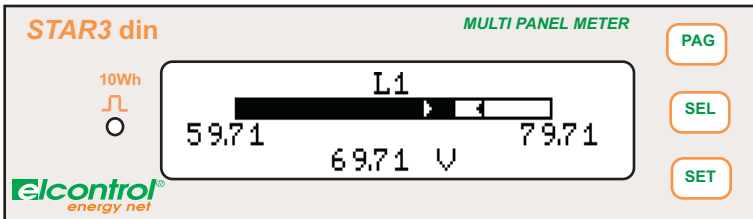

Fig.3

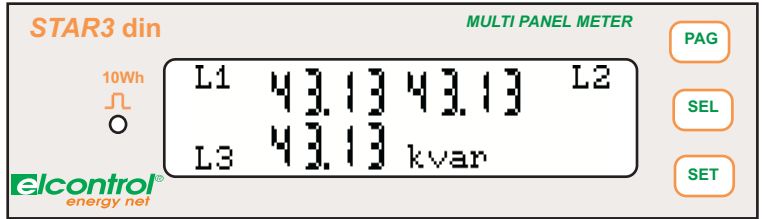

Fig.11

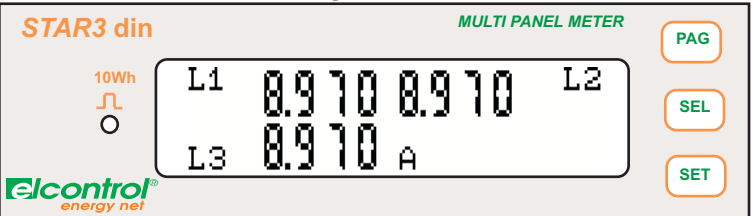

Fig.4

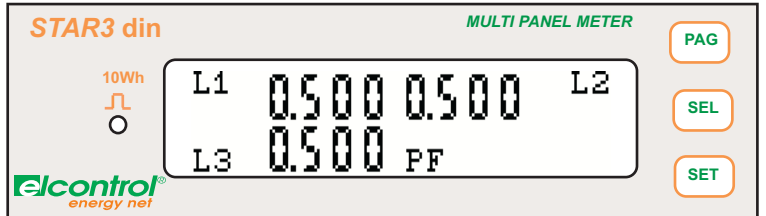

Fig.12

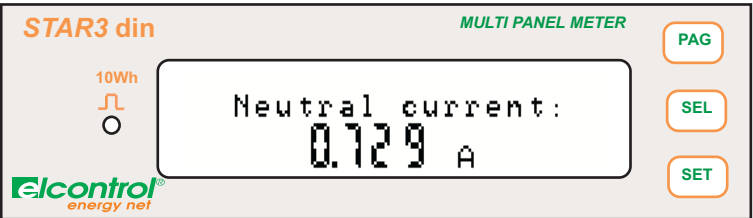

Fig.5

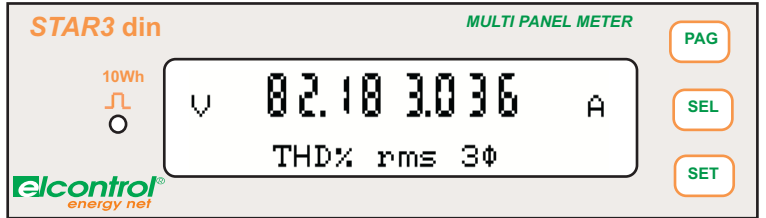

Fig.13

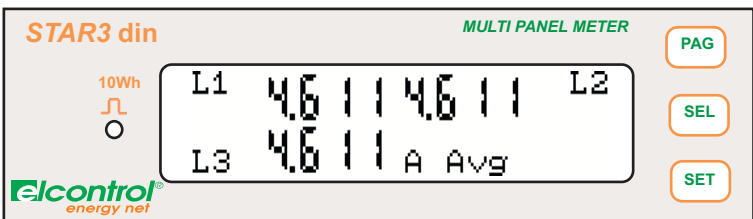

Fig.6

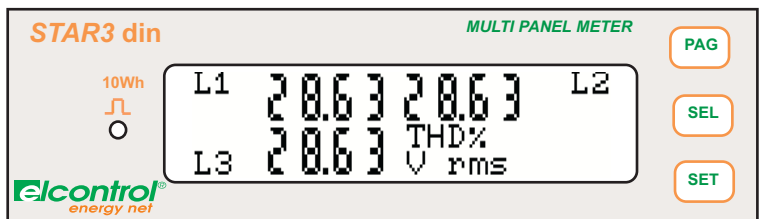

Fig.14

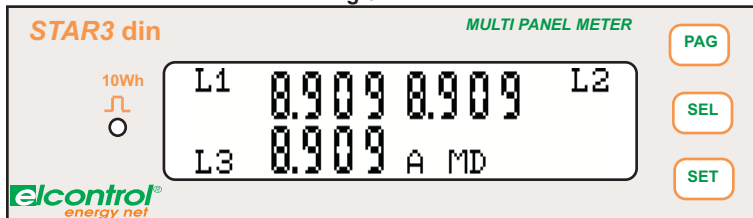

Fig.7

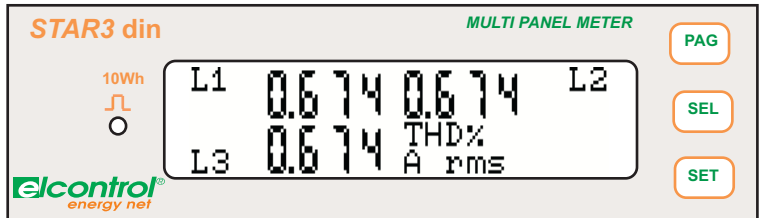

Fig.15

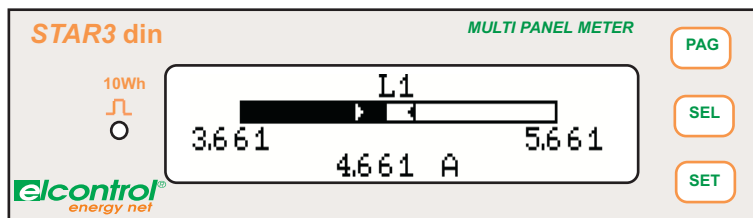

Fig.8

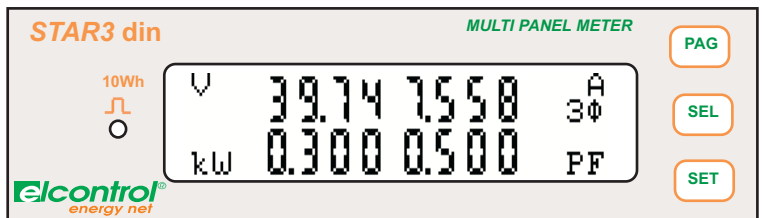

Fig.16

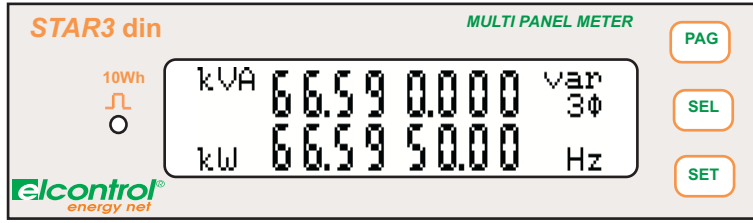

Fig.17

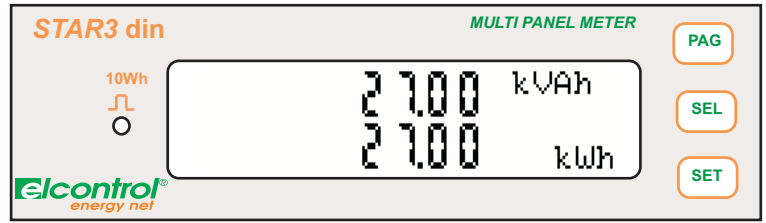

Fig.22



Fig.18

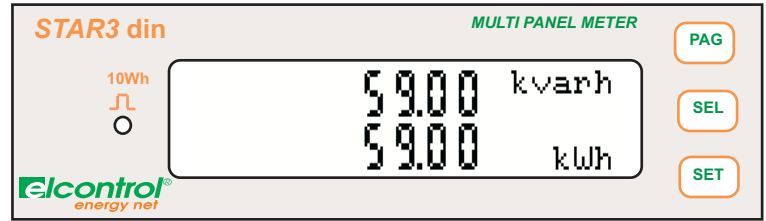

Fig.23



Fig.19

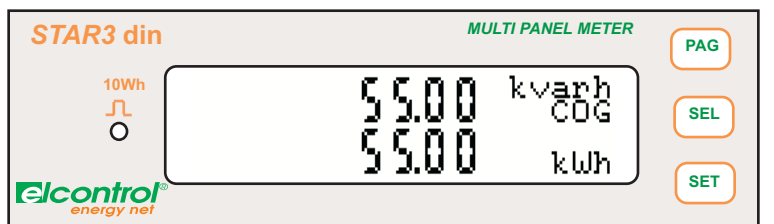

Fig.24

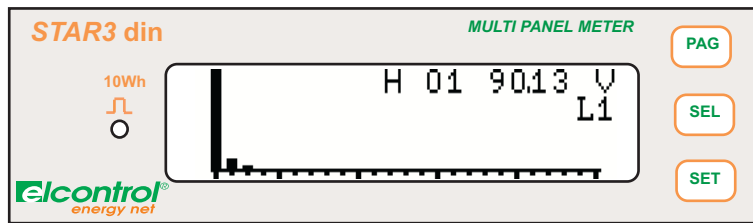

Fig.20

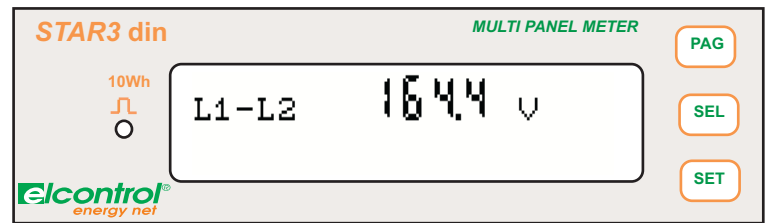

Fig.25

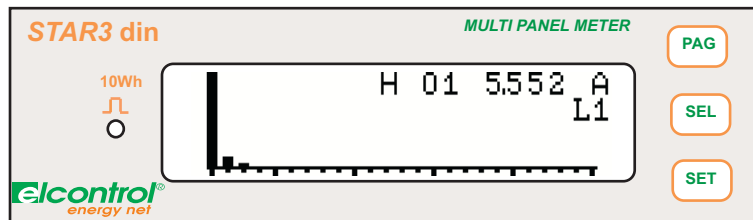
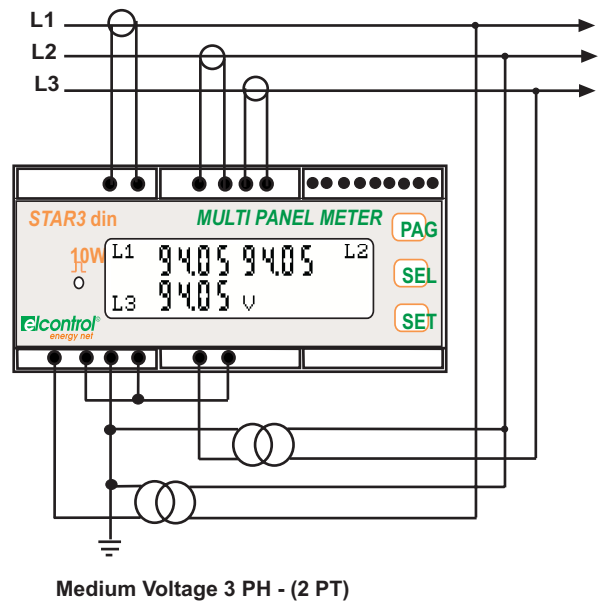
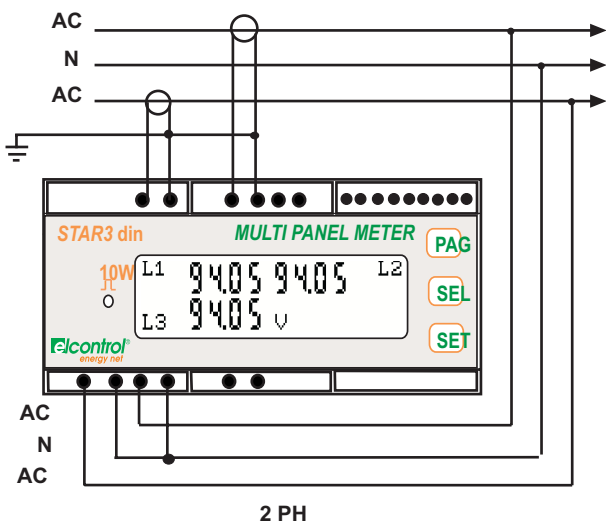
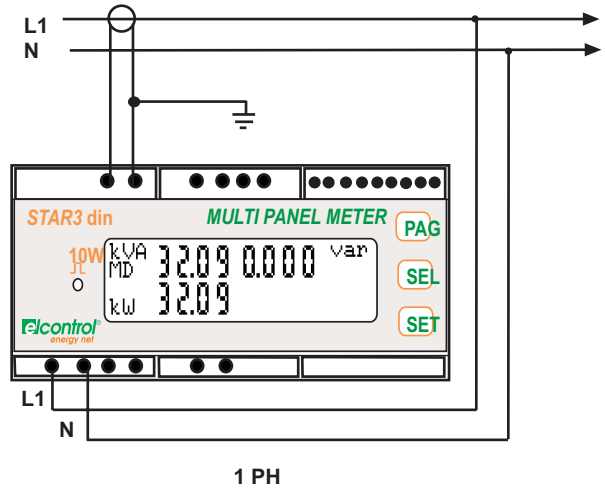
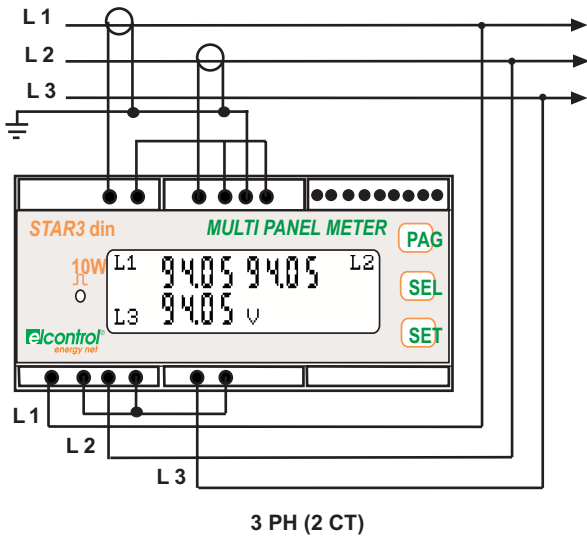
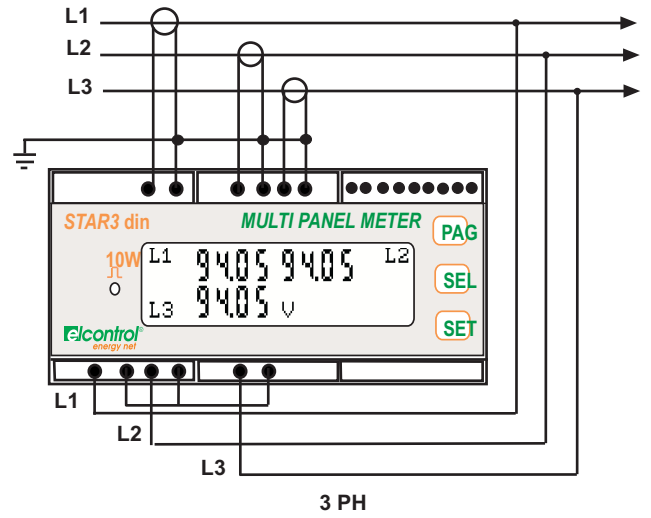
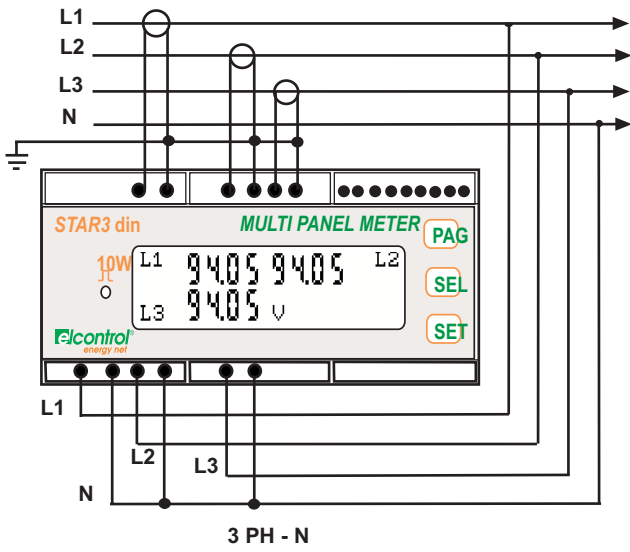
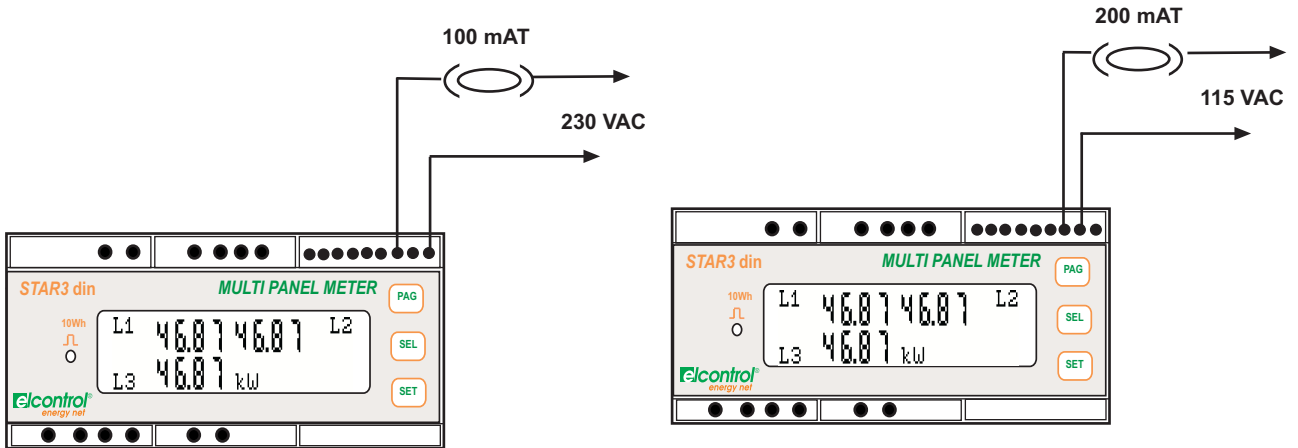

Fig.21

WIRING DIAGRAMS MEASURES INPUTS



POWER SUPPLY CONNECTION



LABELS

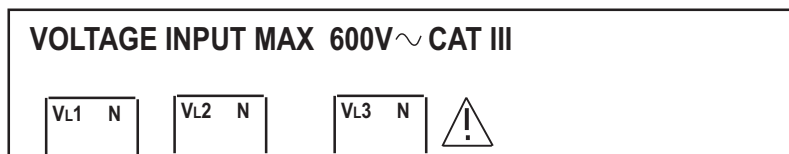
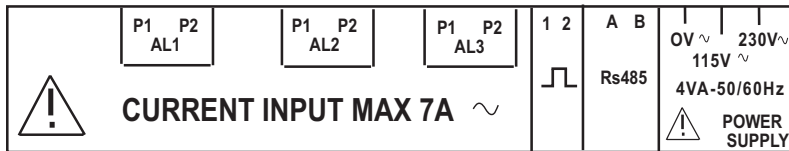

DIMENSIONS

MEASUREMENT CONNECTION CABLES max 4 mm²

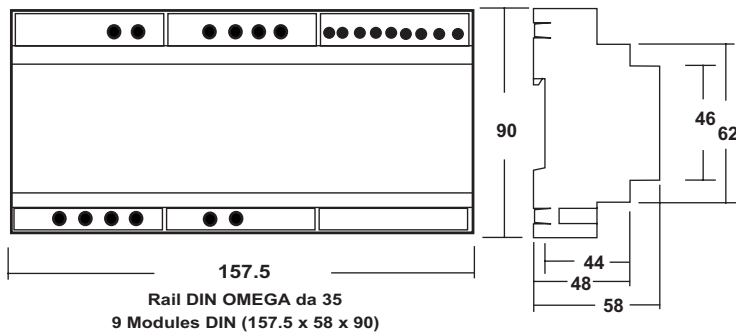

1 - INTRODUCTION

⚠ Please read carefully the instructions with this symbol before installing and using the instrument.

1.1 - STANDARDS and REGULATIONS -

STAR3 DIN conforms to Directive 73/23/CEE (LVD) and 2004/108/CE (EMC).
It has been designed with reference to EN 61010-1, EN 61326 including append. A1/A2/A3, EN 61000-6-2, EN 61000-6-3, EN 61000-3-2, EN 61000-3-3, EN 61000-3-3/A1, EN 61000-4-2, EN 61000-4-3, EN 61000-4-4, EN 61000-4-5, EN 61000-4-5/A1, EN 61000-4-6, EN 61000-4-6/A1, EN 61000-4-8, EN 61000-4-8/A1, EN 61000-4-11, EN 61000-4-11/A1.

1.2 - ⚠ USER SAFETY

In order to preserve these safety conditions and ensure safe operation, the user must observe all instructions and marks specified in this user manual. All maintenance and repair operations requiring the opening of the instrument must be carried out only by suitably qualified and authorised personnel. The instrument was shipped from the manufacturing plant in perfect technical safety conditions.

1.3 - ⚠ PRELIMINARY INSPECTIONS

Before installation, check that the instrument is in good conditions and was not damaged during transport. Check that the network voltage and the rated voltage coincide. This instrument does not require an earth connection.

1.4 - ⚠ PRECAUTIONS IN THE EVENTS OF MALFUNCTIONS

When safe operation is no longer possible, put the instrument out of service and ensure that it cannot be operated accidentally.

Safe operation cannot be guaranteed in the following circumstances:

- When the instrument appears clearly damaged.
- When the instrument no longer works.
- After long storage in unsuitable conditions.
- After being damaged in transit.

2 - CONNECTION OF THE INSTRUMENT

2.1 - ⚠ POWER SUPPLY

The power supply connections terminals are located on the rear side and are clearly indicated with the label POWER SUPPLY. Use cables having a maximum section of 2.5 mm². Earth connection is not required. Follow the connection diagram at the beginning of the manual.

2.2 - ⚠ CONNECTING VOLTAGE MEASUREMENT CABLES

These cables, having a maximum section of 4 mm², are to be connected to the terminals labelled VOLTAGE INPUT as indicated in the diagrams at the beginning of the manual.

2.3 - ⚠ CONNECTING CURRENT MEASUREMENT CABLE

The instrument is able to measure up to 5A only through external C.T. The cables having maximum section of 4 mm² must be connected to the terminals labelled CURRENT INPUT as shown in the diagrams at the beginning of the manual. Use CT's with 5A secondary. Use cables having a section appropriate to the length of the connection and the rated power of the CT's used.

Note 1: For safety reasons, never leave the CT secondary open.

Note 2: Important direct connections, without C.T. will damage the inputs.

3 – MEASUREMENTS PAGES

At power on the STAR3 Din displays the last page selected before the power off. Use the PAG key to scroll through the different measurements and the SEL key to see the details. See the diagrams at page 1, 2, and 3 for the measurements pages. The presence of several pages is depending on the connection mode selected into the setup. [Fig.33].

3 PH-N	=	Three-phases with neutral, i.e. Star, 4 wires system (Star)	diagram page 1
3 PH	=	Three-phases without neutral, i.e. Delta, 3 wires system (Delta)	diagram page 1
2 PH	=	Two-phases and neutral (Diphase)	diagram page 2
1 PH	=	Single-phase and neutral (Single-Phase)	diagram page 3

[Fig. 1]

3 PH-N, 3 PH	=	Phase-neutral voltages	VL1-N, VL2-N, VL3-N
2 PH	=	Phase-neutral voltages	VL1-N, VL2-N
1 PH	=	Page not appearing	

[Fig. 2]

Page appearing only in Three phases without neutral (Delta).
3 PH = Phase-phase voltages VL1-L2, VL2-L3, VL3-L1

[Fig. 3]

Graphics of the maximum, minimum and instantaneous value of the phase voltage. In the central part of the page you can see the phase the graphic refers to

[Fig. 4]

3 PH-N, 3 PH = Phase currents AL1, AL2, AL3
2 PH = Phase currents AL1, AL2
1 PH = Page not appearing

[Fig. 5]

Neutral current $I_{neutral}$ appearing only in 3 PH-N; 3 PH.

[Fig. 6]

3 PH-N, 3 PH = Average phase current AL1Avg, AL2Avg, AL3Avg
2 PH = Average phase current AL1Avg, AL2Avg
1 PH = Page not appearing

Note: The integration time is the same used for the Average power and it is adjustable into the SETUP menu [Fig.29].

[Fig. 7]

3 PH-N, 3 PH = Phase current peaks AL1MD, AL2MD, AL3MD
2 PH = Phase current peaks AL1MD, AL2MD,
1 PH = Page not appearing

[Fig. 8]

As in [Fig.3] but refers to the currents.

[Fig. 9]

3 PH-N, 3 PH = Phase active powers PL1, PL2, PL3
2 PH = Phase active powers PL1, PL2
1 PH = Page not appearing

[Fig. 10]

3 PH-N, 3 PH = Phase Apparent powers SL1, SL2, SL3
2 PH = Phase Apparent powers SL1, SL2
1 PH = Page not appearing

[Fig. 11]

3 PH-N, 3 PH = Phase reactive powers QL1, QL2, QL3
2 PH = Phase reactive powers QL1, QL2
1 PH = Page not appearing

[Fig. 12]

3 PH-N, 3 PH = Phase Power Factor PFL1, PFL2, PFL3
2 PH = Phase Power Factor PFL1, PFL2
1 PH = Page not appearing

[Fig. 13]

Average Total Harmonic Distortion Factors in %
 $THD\%V = (THD\%VL1 + THD\%VL2 + THD\%VL3) / 3$
 $THD\%A = (THD\%AL1 + THD\%AL2 + THD\%AL3) / 3$
Note These special parameters allow to identify immediately if one of the phases is distorted

[Fig. 14]

3 PH-N, 3 P = Phase Total Harmonic Distortion THD%V1, THD%V2, THD%V3
2 PH = Phase Total Harmonic Distortion THD%V1, THD%V2
1 PH = Page not appearing

THD%V1 =

$$\frac{\sqrt{\sum_{h=2}^{25} V_{1h}^2}}{V1_{rms}} = \frac{\sqrt{(V1_{rms}^2 - V1_{fund}^2)}}{V1_{rms}}$$

[Fig. 15]

3 PH-N, 3 PH	=	Phase Total Harmonic Distortion	THD%A1, THD%A2 ; THD%A3
2 PH	=	Phase Total Harmonic Distortion	THD%A1, THD%A2
1 PH	=	Page not appearing	
THD%A1=			

$$\frac{\sqrt{\left(\sum_{h=2}^{25} A_h^2\right)}}{A_{1\text{rms}}} = \frac{\sqrt{(A_{1\text{rms}}^2 - A_1^2)}}{A_{1\text{rms}}}$$

[Fig. 16]

Equivalent three-phase voltage	V = (VL1-N + VL2-N + VL3-N) / 3	(3 PH-N)
Equivalent three-phase voltage	V = (VL1-L2 + VL2-L3 + VL3-L1) / 3	(3 PH)
Phase to phase voltage	V = VL1-N + VL2-N	(2 PH)
Phase-Neutral voltage	V = VL1-N	(1 PH)
Equivalent three-phase current	A = S / (3 V)	(3 PH-N, 3 PH)
	A = S / V	(2 PH)
	A = AL1	(1 PH)
Total Active power	P = PL1 + PL2 + PL3	(3 PH-N, 3 PH)
	P = PL1 + PL2	(2 PH)
	P = PL1	(1 PH)
Power factor	P.F. = P / S	

[Fig. 17]

Apparent power	S = (P ² + Q ²)	
Total Reactive power	Q = QL1 + QL2 + QL3	(3 PH-N, 3 PH)
Total Reactive power	Q = QL1 + QL2	(2 PH)
Total Active power	see fig. 16	
Frequency (di VL1)	f (Hz)	

[Fig. 18]

Average apparent power	S avg
Average reactive power	Q avg
Average active power	P avg

Note: The integration time can be adjusted into the Setup menu [Fig. 29]. The average values can be reset into the Setup menu [Fig. 31].

[Fig. 19]

Maximum demand apparent power	S MD
Maximum demand reactive power	Q MD
Maximum demand average power	P MD

Note: The peaks values can be reset into the Setup menu [Fig. 31].

[Fig. 20]

Graphic display of the voltage harmonics referring to the single-phases.
 Use the SEL and SET keys to scroll through the measured values of the harmonics appearing on the right top of the page. Example : H 05 90.32 V L2 means the 5th voltage harmonics of phase 2 has a value of 90.32 Volt.
 Note : This page appears only in the HARMO model.

[Fig. 21]

As in fig. 20 but refers to the currents harmonics .

[Fig. 22]

Total apparent energy counter	kVAh
Total active energy counter	kWh

Note: range 0,000,000.00-99,999,999.9. When the upper limit is reached, the counter restarts from 0.00.

[Fig. 23]

Total reactive energy counter	kvarh
Total active energy counter	kWh

Note: range 0,000,000.00-99,999,999.9. When the upper limit is reached, the counter restarts from 0.00.

[Fig. 24]

This page appears only if COG is enabled in the SETUP menu [Fig. 32].
 Cogeneration counters.
 Total reactive energy kvarh
 Total exported active energy kWh
 Note: o measure properly the cogeneration counters it is strictly necessary to connect the CTs oriented in the same direction.

[Fig. 25] Phase-phase Voltage VL1-L2. It appears only in 2 PH.

4 – SETUP PAGES (ALL THE MODELS)

Programming the instrument through the SETUP menu. Use the PAG and SEL keys to access the Programming mode (SETUP menu).

See also the diagram on page 8 reading this chapter

4.1 – SETUP PAGE PROTECTION CODE

By default, the access code to set-up pages is not enabled. To enable it, keep the PAG + SEL keys pressed at the same time for 30 sec. The display will show the page on which the access code must be entered. [Fig.26].

[Fig. 26]

By means of the SEL + SET keys, every digit can be changed and the code can be entered. The initial factory code, that must be entered the first time is 000000. Confirm and exit from this page by pressing the PAG key.

Now a second page (with "COD" blinking), identical to the first one, is displayed:

From this page, the access code can be permanently changed, if wished.

In this case remember or make a safe note of the new code somewhere you can find it later on.

To exit from the second page press the PAG key.

IMPORTANT: After the first access to the password page, the request of the code will become permanent.

From that moment on the code must be always entered to access the set-up page.

Avoid to recall the password page, for test purposes, if the code request is not permanently desired.

STAR3 DIN PASSWORD SETUP MEMO	
Serial Number Installed At	
Factory Password	000000
Date New Password	
Date New Password	
Date New Password	

4.2 – SETUP PAGES

To access SETUP pages press the PAG and the SEL keys at the same time. Press the PAG key to access the next page, press the SEL key to select a digit or a setting. Use the SET key to adjust it. The SETUP can be protected with a password (see paragraph 4.1).

[Fig. 27]

Programming Primary / Secondary of the Voltage Transformers (VT). Use a ratio equal to 1 (e.g. 100/100) in case of direct measures without voltage transformer. Select a digit with the SEL key; change its value using the SET key.

[Fig. 28]

Programming Primary / Secondary of the Current Transformers (CT). Use a ratio equal to 1 (e.g. 5/5) in case of direct measures without current transformer. Select a digit with the SEL key; change its value using the SET key.

[Fig. 29]

Integration Time of the average Power and Current settable from 0 to 99 minutes. Select a digit with the SEL key; change its value using the SET key.

[Fig. 30]

Energy counters Reset

If you select YES with the SET key, all the counters will be reset as soon you confirm by pressing the PAG. key.

[Fig. 31]

Reset of the average and maximum demand, Power and e Current.

If you select YES with the SET key, all the counters will be reset as soon you confirm by pressing the PAG. key.

[Fig. 32]

Enable Cogeneration counters.

Select ON or Off to enable the measures and confirm with PAG

To measure properly the cogeneration counters it is strictly necessary to connect the CTs oriented in the same direction.

[Fig. 33]

Programming connection type

Select the type of system which you want to measure using the SET key.

Delta = Three phases without neutral (i.e. Delta) (3 PH)

Star = Three phases with neutral (i.e. Star) (3 PH-N)

Diphase = Two-phases with neutral (2 PH)

Single-Phase = Single phase with neutral (1 PH)

[Fig. 34]
Rs485 communication parameters set-up.
Baud Rate can have the following values: 2400, 4800, 9600, 19200 (bps)
The Parity (central) value can be: N(none), O(odd), E(even).
The type of communication protocol Modbus (3 bottom digits) can be:
ASCII = Modbus ASCII. This format is limited to simulate the same data frame of the Vip Energy.
BCD = Modbus BCD MODICON protocol
IEEE = Modbus IEEE standard, INTEL format

[Fig. 35]
Modbus address of the instrument. The permitted address field ranges between 1 and 247

5 – ADDITIONAL SETUP PAGES FOR MODELS STAR3 din ALM e STAR3 din HARMO

These models are equipped with a programmable relay output. See the diagram at page 9 for the programming. To access the Programming Mode, see the previous paragraphs.

[Fig. 36]
Models with relay output have two way of functioning :
Relay: alarms/relay mode (see paragraph 5.1).
Pulse Mode: pulse mode (see paragraph 5.2). 100 mSec = Enable Pulse mode with pulse length of 100 mSec. (see chap. 7.1 for the programming)
Relay = The confirmation of this page enable the remote relay control or the alarm mode.

5.1 - RELAYS or ALARM OUTPUT

Choosing relay on page [Fig. 36] enables to go to the programming of the output 1 intervention mode.

[Fig. 37]
Association of the output 1 with a measures for alarm controlling. Press the SET key to choose the relay option or one of the measures of Tab. 1 at page 9. Pressing the PAG key enables to go to page of [Fig.38].
Note: Some of the measures are not carried out in 1PH, 2PH and 3PH mode.
The selection of the Relay option involves the remote control of the relay output through the commands sent to the Rs485 serial line. In this case it is not necessary to insert other information : press the PAG key to exit the SETUP .

[Fig. 38]
Set-up of the upper threshold (H) of the selected measure. (Tab.1). When the measure remain above the threshold + hysteresis , for a time longer than the requested delay, the relay 1 is closed, range 0 - 999 x 10⁶.

[Fig. 39]
Set-up of the lower threshold (L) of the selected measure. When the measure remain below the threshold hysteresis , for a time longer than the requested delay, the relay 1 is closed, range 000-999 x 10⁶.

[Fig. 40]
Set-up of the hysteresis value expressed as a % (percentage). Admitted value from 0% to 99% of the alarm threshold. The alarm condition is acknowledged only if the measure become higher than Threshold*(1+hysteresis%)

[Fig. 41]
Set-up of the delay figure output 1 (relay closed) The alarm will toggle only if the new alarm condition persist for a time longer than the delay. Delay figure from 0 to 999 seconds.

5.2 – PULSES OUTPUT

Choosing 100mSec (pulse mode) at page [Fig. 36] the Programming Mode of output 1 is selected.

[Fig. 42]
Measure corresponding to the pulse output 1. Selectable measures: kWh, kvarh , kVAh.
Cogenerated kWh and kvarh appear when the cogeneration mode is enabled..

[Fig. 43]
Set-up of the pulse length output 1. E.g. : selecting 0.01 kWh value = 1 pulse for 0.01 kWh energy consumption.

6 – ADDITIONAL SETUP PAGES FOR MODEL STAR3 Din 4-20mA

This model is equipped with two programmable. For the programming see diagram on page 9.
To access the Programming Mode, see the previous chapters.

·[Fig. 44]

By pressing the SET key the type of output (4-20mA or 0-20mA) can be selected.
Pressing the PAG key enables to go to the measure selection page of output 1.

·[Fig. 45]

Output 1 measure selection. Pressing the SET key enables to select one of the measures listed on Tab. 2
page 10.

Press the PAG key to go measures selection page of output 2.

·[Fig. 46]

The same of [Fig.45] but refers to output 2.

·[Fig. 47]

Output 1 full scale set up.

Pressing the SEL key to select the exponent or digit to modify.

Pressing the SET key to select the exponent or digit to modify.

Pressing the PAG key enable to go to the output 2 end value set-up page.

·[Fig. 48]

The same of [Fig.47] but refers to output 2.

7 – TECHNICAL CHARACTERISTICS

Maximum dimensions (mm): instrument: 157,5 x 58 x 90

Power supply: from network 230 V 115 V +15% - 20% @ da 50/60 Hz (4 VA)

Display: LCD display dot matrix

Voltmeter inputs: 600V CAT. III (750V CAT. II), 35+400 Hz

Voltmeter input impedance: 2 M

Voltage input overload : max 850 V phase-neutral

Current inputs: AL1, AL2, AL3, COM. Consumption 1 VA. external curr. transf required (see diagrams)

Measuring range: 0-120% nominal current

Sensitivity: current 20 mA ; voltage 10 V

Over current : withstand 50 amps for 1 sec.

Number of scales: 1 voltage scale, 2 current scales

Measurements: True R.M.S. up to 25th harmonic = 1250Hz with fundamental @50 Hz

Sampling frequency: 2.5 kHz

Accuracy: < 0,5% for V, I and Power

Connection: Single phase or three phase star, three phase delta, or diphas systems

Weight : 0.6 Kg

Protection level: instrument IP20, front panel IP40

Temperature range: -10°C ÷ + 50°C

Relative humidity range: (R.H.): from 20% to 90%.

Condensation: non condensing

Relay output: 100VAC max, 120mA AC max

8 - RS485 SERIAL OUTPUT

Standard Rs485, max 32 instruments on each line without signal repeater, up to 247 instrument with signal repeater.