

ENGLISH

VIP 396



Multi Panel Meter

USER MANUAL

WARNING - ELCONTROL ENERGY NET declines all liability for any damage to people or property caused by unsuitable or incorrect use of its products. Elcontrol Energy Net reserves the right to change product specifications without prior notice.



Pg. M1: VL1, VL2, VL3
(three-phase only)

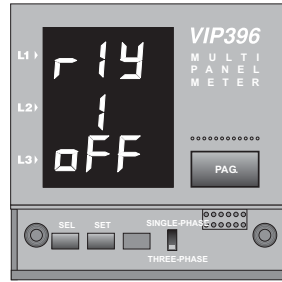

Pg. M1 R1: Relay 1
output status

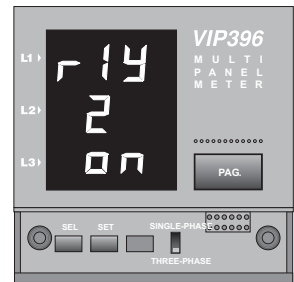

Pg. M1 R2: Relay 2
output status



Pg. M2: AL1, AL2, AL3
three-phase only)



Pg. M2n: A neutral
(three-phase only)



Pg. M3: P1, P2, P3
(three-phase only)



Pg. M4: S1, S2, S3
(three-phase only)

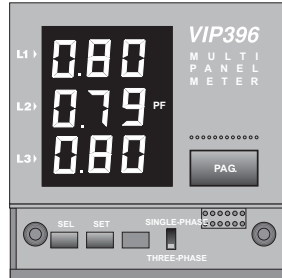

Pg. M5: P.F.1, P.F.2, P.F.3
(three-phase only)

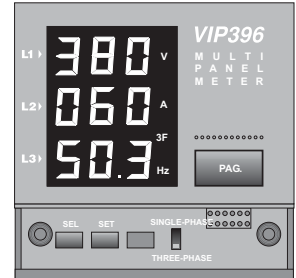

Pg. M6: V, A, Hz
(three and single phase)

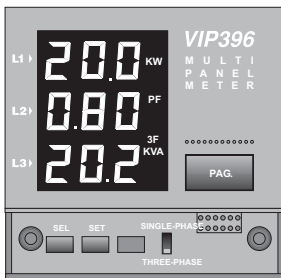

Pg. M7: P, P.F., S
(three and single phase)

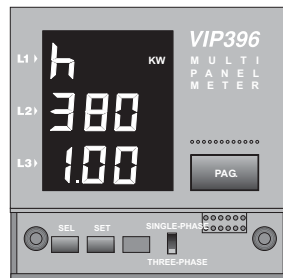

Pg. M8: kWh

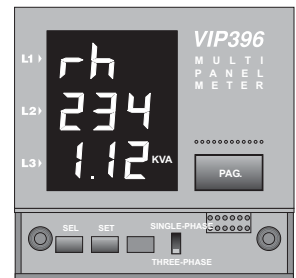

Pg. M9: kVAh



Pg. M10: kVAh

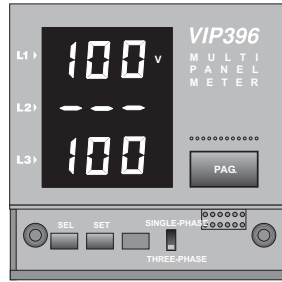

Pg. S1: PT / TV SETUP

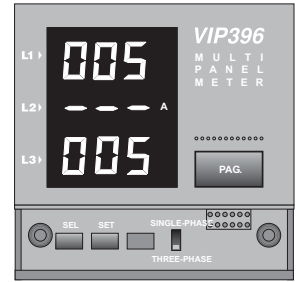

Pg. S2: CT / TA SETUP

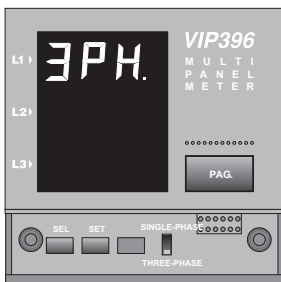

Pg. S3a : 3 Wire / 3 Fili

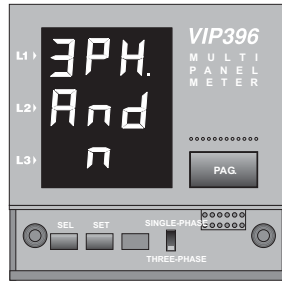

Pg. S3b: 4 Wire / 4 Fili

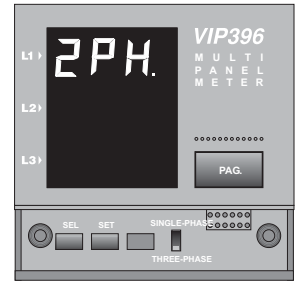

Pg. S3c: 2 Phase / Bifase

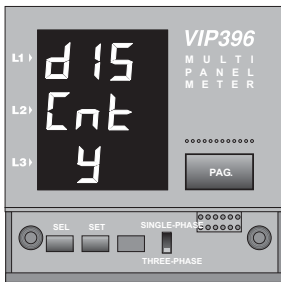

Pg. S4: Enable Counters



Pg. S5: Reset Counters

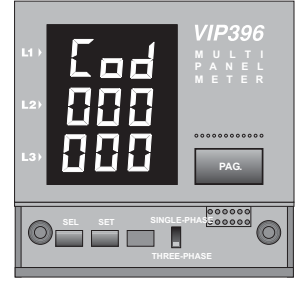

Password

WIRING DIAGRAMS MEASURES INPUTS

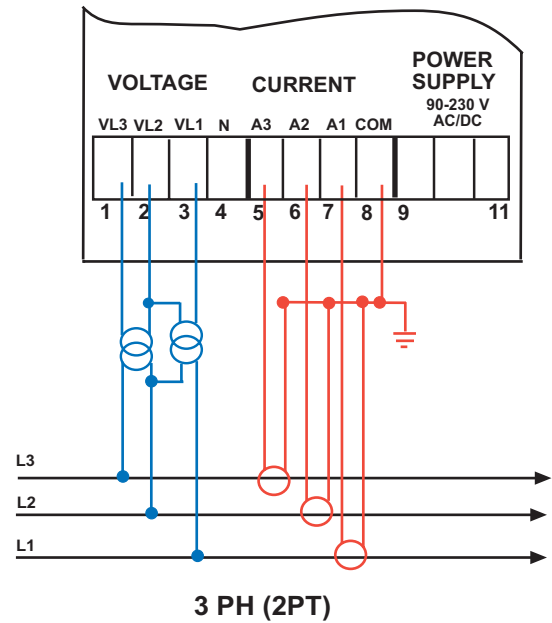
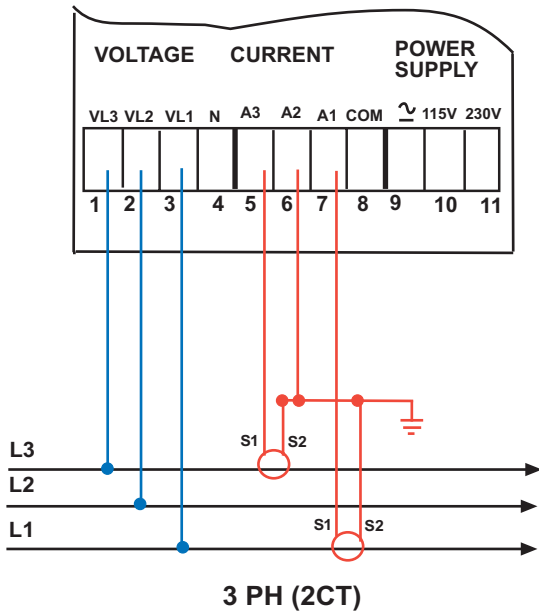
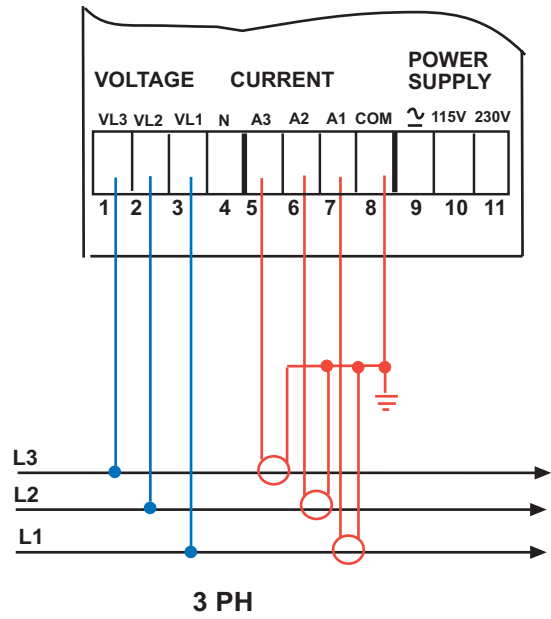
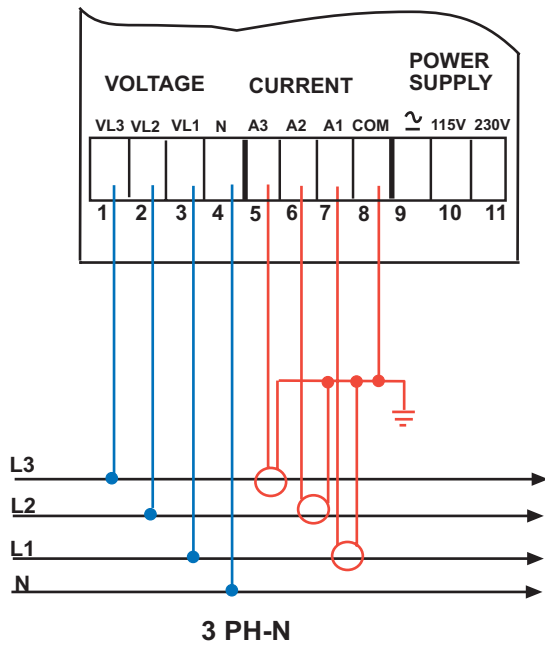

⚠ NOTE: The secondary side of the PT is not grounded. Further protection may be required.

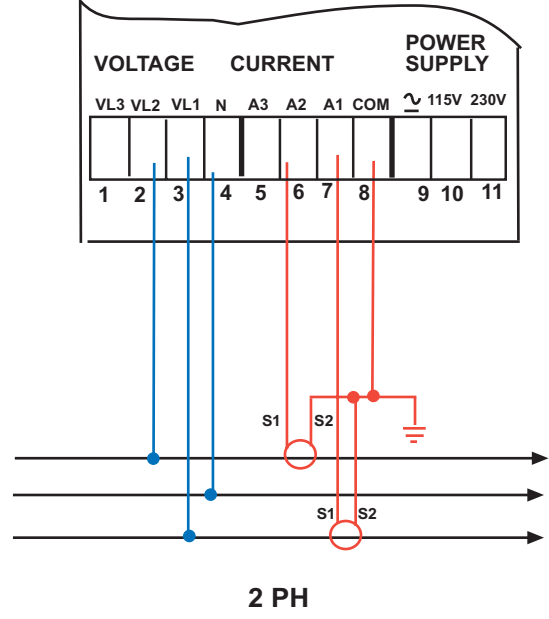
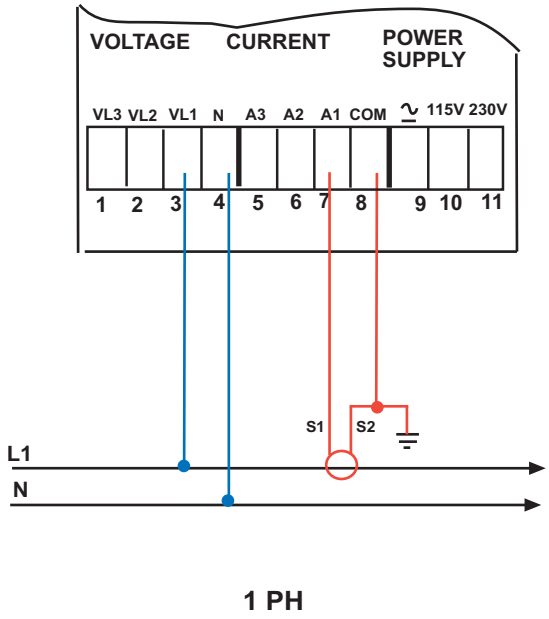

POWER SUPPLY CONNECTION

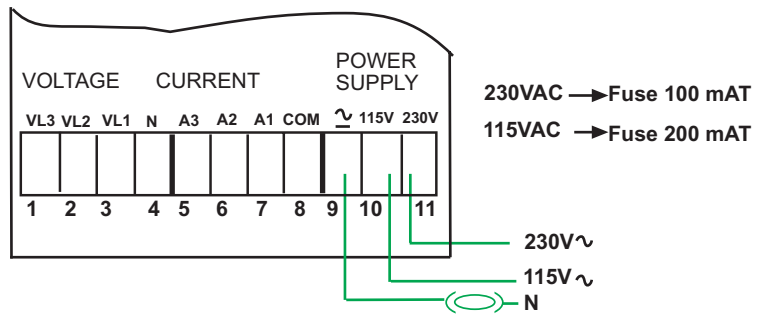

DISPLAYED MEASUREMENT

PARAMETERS	TOT	L1	L2	L3	N
V
A
kW
kvar
kVA
P.F.
Hz
kWh
kVArh
kVAh

1 - INTRODUCTION

 Please read carefully the instructions with this symbol before installing and using the instrument.

1.1 - STANDARDS and REGULATIONS

The VIP396 family of products conforms to Directive 73/23/CEE (LVD) and 2004/108/CE (EMC). It has been designed with reference to EN 61010-1, EN 61326 including append. A1/A2/A3, EN 61000-6-2, EN 61000-6-3, EN 61000-3-2, EN 61000-3-3, EN 61000-3-3/A1, EN 61000-4-2, EN 61000-4-3, EN 61000-4-4, EN 61000-4-5, EN 61000-4-5/A1, EN 61000-4-6, EN 61000-4-6/A1, EN 61000-4-8, EN 61000-4-8/A1, EN 61000-4-11, EN 61000-4-11/A1.

1.2 - USER SAFETY

In order to preserve these safety conditions and ensure safe operation, the user must observe all instructions and marks specified in this user manual. All maintenance and repair operations requiring the opening of the instrument must be carried out only by suitably qualified and authorised personnel. The instrument was shipped from the manufacturing plant in perfect technical safety conditions.

1.3 - PRELIMINARY INSPECTIONS

Before installation, check that the instrument is in good conditions and was not damaged during transport. Check that the network voltage and the rated voltage coincide. This instrument does not require an earth connection.

1.4 - PRECAUTIONS IN THE EVENTS OF MALFUNCTIONS

When safe operation is no longer possible, put the instrument out of service and ensure that it cannot be operated accidentally.

Safe operation cannot be guaranteed in the following circumstances:

- When the instrument appears clearly damaged.
- When the instrument no longer works.
- After long storage in unsuitable conditions.
- After being damaged in transit.

2 - CONNECTION OF THE INSTRUMENT

2.1 - POWER SUPPLY

The power supply connections terminals are located on the rear side and are clearly indicated with the label POWER SUPPLY. Use cables having a maximum section of 2.5 mm². Earth connection is not required. Follow the connection diagram at the beginning of the manual.

2.2 - CONNECTING VOLTAGE MEASUREMENT CABLES

These cables, having a maximum section of 2.5 mm², are to be connected to the terminals labelled VOLTAGE INPUT as indicated in the diagrams at the beginning of the manual.

2.3 - CONNECTING CURRENT MEASUREMENT CABLE

The instrument is able to measure up to 5A only through external C.T. The cables having maximum section of 2.5 mm² must be connected to the terminals labelled CURRENT INPUT as shown in the diagrams at beginning of the manual. Use Use 3 CT's with 5A secondary. Use cables having a section appropriate to the length of the connection and the rated power of the CT's used.

Note 1: For safety reasons, never leave the CT secondary open.

Note 2: Important direct connections, without C.T. will damage the inputs.

3 - PROGRAMMING THE INSTRUMENT

The instrument can be programmed using the PAG, SEL, SET keys and the SINGLE-PHASE / THREE-PHASE selector switch, located on the front panel.

At power on, the VIP396 displays the last page selected before power off.

Using the selector switch, select the type of system connected: Single phase system (SINGLE-PHASE) or three phase or diphas system (THREE-PHASE).

Use the PAG key to scroll through the different measurement pages.

To access SETUP mode, press at the same time the PAG and the SEL keys.

The parameters are programmed with the SEL and SET keys.

Use the PAG key to scroll through the various SETUP pages and return to the Measurement page.

The type of connection is configured in SETUP:

- 3 PH and N (Three phases with neutral, i.e. Star or 4 wires);
- 3 PH (Three phases without neutral, i.e. Delta or 3 wires);
- 2 PH Two phase.

4 –SETUP PAGE PROTECTION CODE

By default, the access code to set-up pages is not enabled. To enable it, keep the PAG + SEL keys pressed at the same time for 30 sec. The display will show the page on which the access code must be entered.

By means of the SEL + SET keys, every digit can be changed and the code can be entered. The initial factory code, that must be entered the first time is 000000. Confirm and exit from this page by pressing the PAG key.

Now a second page (with "COD" blinking), identical to the first one, is displayed:

From this page, the access code can be permanently changed, if wished.

In this case remember or make a safe note of the new code somewhere you can find it later on.

To exit from the second page press the PAG key.

IMPORTANT: After the first access to the password page, the request of the code will become permanent. From that moment on the code must be always entered to access the set-up page.

Avoid to recall the password page, for test purposes, if the code request is not permanently desired.

5 - MEASUREMENT PAGES

Use the PAG key to scroll through the different measurement pages.

·Page M1 (page appearing only in THREE-PHASE)

Phase-neutral voltages	VL1-N, VL2-N, VL3-N	(3 PH And n)
Phase-phase v	V12, V23, V31	(3 PH)
Phase-neutral voltages	VL1-N, VL2-N	(2 PH)

·Page M1 R1 (page present only if ALM present)

Status of Relay output 1

From Pg. M1 Press the SEL key to view status of Relay 1 output.

·Page M1 R2 (page present only if ALM present)

Status of Relay output 2

From Pg. M1 R1 Press the SEL key to view status of Relay 2 output.

·Page M2 (page appearing only in THREE-PHASE)

Phase currents	AL1, AL2, AL3	(3 PH And n, 3 PH)
Phase currents	AL1, AL2	(2 PH)

·Page M2n (present only in THREE-PHASE, pressing the SEL key from page M2)

Neutral current A neutral

·Page M3 (page appearing only in THREE-PHASE)

Phase active powers	P1, P2, P3	(3 PH And n, 3 PH)
Phase active powers	P1, P2	(2 PH)

·Page M4 (page appearing only in THREE-PHASE)

Apparent phase powers	S1, S2, S3	(3 PH And n, 3 PH)
Apparent phase powers	S1, S2	(2 PH)

·Page M5 (page appearing only in THREE-PHASE)

Phase power factors	P.F.1, P.F.2, P.F.3	(3 PH And n, 3 PH)
Phase power factors	P.F.1, P.F.2	(2 PH)

·Page M6 Three or Single-phase equivalent. measurement (THREE or SINGLE-PHASE)

Equivalent. three-phase voltage	$V = (VL1-N + VL2-N + VL3-N) / 3$	(3 PH And n)
Equivalent. three-phase voltage	$V = (V12 + V23 + V31) / 3$	(3 PH)
Phase to phase voltage	$V = VL1-N + VL2-N$	(2 PH)
Equivalent. three-phase current	$A = S / (3 V)$	(3 PH And n, 3 PH)
Current	$A = S / V$	(2 PH)
Frequency of VL1 in Hz	f	

·Page M7 Three-phase or Single-phase measurements (THREE or SINGLE-PHASE)

Active power	$P = P1 + P2 + P3$	(3 PH And n)
Active power	$P = P1 + P2$	(3 PH, 2 PH)
Power factor	$P.F. = P / S$	
Apparent power	$S = (P^2 + Q^2)$ (with Q = sum of phase reactive powers)	

·Page M8 Three-phase active energy counter kWh

Appears only if display was enabled in the set-up.

range 0000.00-999999 kWh. When the upper limit is reached, the counter restarts from 000000 kWh. Decimals disappear definitively after the first roll-over.

It must be reset to display decimals again.

·Page M9 Three-phase reactive energy counter kVAh

The display method is identical to that of the kWhs

·Page M10 Three-phase apparent energy counter kVAh

The display method is identical to that of the kWhs

6 - SETUP PAGES

To access Programming Mode,

open the front door and press the PAG and the SEL keys at the same time:
use then the SEL key to select a digit, and the SET key to increment it.

- Page S1 Programming the Primary and Secondary Windings of a PT
Select a digit with the SEL key; change its value using the SET key.
- Page S2 Programming the Primary and Secondary Windings of a CT
Select a digit with the SEL key; change its value with the SET key.
- Page S3 (present only in THREE-PHASE) Programming connection type
Select the type of system which you want to connect to using the SET key.
 - Page S3a 3 PH Three phases without neutral (i.e. Delta)
 - Page S3b 3 PH And n Three phases with neutral (i.e. Star)
 - Page S3c 2 PH Two-phase
- Page S4 Enabling energy counters display
The SET key is used to enable display of the energy counters. The counters are displayed as a factory default setting.
- Page S5 Resetting energy counters.
If you select Y with the SET key, the counters will be reset as soon you confirm by pressing the PAG.
key.
This page is displayed only if counter display was requested on S4.

7 - TECHNICAL CHARACTERISTICS

Maximum dimensions (mm): instrument: 96 X 96 X 115.4. Cut-out template: 91 X 91

Power supply: from network 230 V or 115 V 10% @ from 50 to 400 Hz (4 VA)

Display: Seven-segment 13 mm red LED's , 3 digit on 3 lines

Voltmeter inputs: VL1, VL2, VL3, N up to 430 V phase-neutral, 750 V phase-to-phase, 35400 Hz.

Voltmeter input impedance: 2 M

Voltage input overload: max 850 V phase-neutral

Amperometric inputs: AL1, AL2, AL3, COM. Consumption 1 VA. Three / 5A external curr.transf. required

Amper. input overload: max 7 A

Number of scales: 1 voltage scale, 2 current scales

Measurements: T.R.M.S. (true root mean square) up to 24th harmonic (50 Hz), 20th (60 Hz)

Precision: 1% reading per V and I; 1% for power

Suitable for connection to: Single phase or three phase star, three phase delta, or diphas systems

Weight of instrument: 0.6 Kg

Protection level: instrument IP20, front panel IP30

Ambient temperature range: -10°C + 60°C

Relative humidity range (R.H.): from 20% to 80%.

Condensation: non condensing.

DIMENSIONS

