

INSTRUCTIONS

1 SAFETY

This instrument is manufactured in compliance with EN61010-1 Cat III for nominal operating voltages of 400V L-L and 230V L-N, to ensure safe operation the user must comply with the following instructions:

- Ensure that the supply voltage is correct.
- The auxiliary mains supply is internally fused at 250V, 100mA Type 2, external fusing is required if the auxiliary supply voltage exceeds 250V.
- Maintenance and/or repairs must be carried out only by qualified, authorised personnel.
- If there is ever the suspicion that safe use is no longer possible, the instrument must be disconnected and precautions must be taken against accidental use.
- Operation is no longer safe when:
 - 1) If there is clearly visible damage
 - 2) If the instrument no longer functions
 - 3) After prolonged storage in unsuitable conditions.

1.1 OPERATOR SAFETY

Read these instructions carefully before installing and utilising the instrument.

The instrument described in this user manual is intended for use by properly trained staff only. Maintenance and/or repairs must be carried out by authorised personnel only. For proper, safe use of the instrument and for maintenance and/or repair, it is essential that the persons instructed to carry out these procedures follow normal safety precautions.

2 SYMBOLS



CAUTION: Failure to follow the instructions may result in personal injury or damage to equipment.



NOTE: Failure to follow the instructions may result in an instrument malfunction.

3 CONNECTION DIAGRAMS

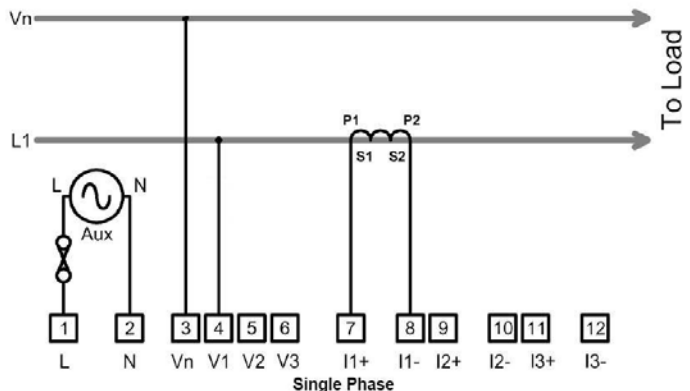
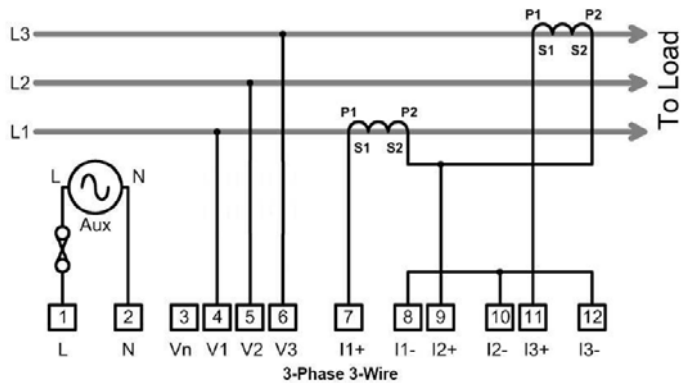
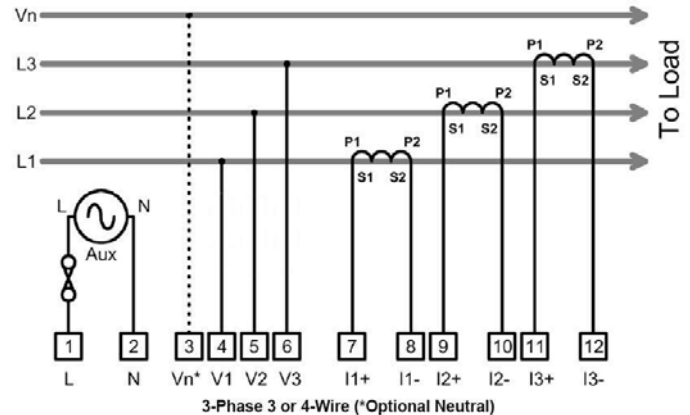

CAUTION: The instrument is internally fused at 250V 100mA. External fusing is required if the supply voltage exceeds 250V.

3.1 CONNECTION OF THE CURRENT INPUT

The AEM32 is suitable for use with current transformers (CTs) with 5A secondary output. Metering quality CTs of Class 1 accuracy with a minimum rating of 2.5VA are recommended.

Connections should be made according to the diagrams above.

3.2 PULSE OUTPUT CONNECTIONS

CAUTION:

The pulse output contacts are rated at 100mA AC/DC, 100V max. Under no circumstances should this rating be exceeded.

The output has a telltale l.e.d. on the front panel which flashes 'on' to indicate a pulse being generated.

The pulse connections are as follows:
Terminals 13 & 14

The contacts are volt free and therefore an external power supply must be provided.

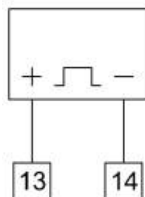



4 INSTRUMENT OPERATION

When the instrument is powered up, the display will initially show the internal software version, then after a few seconds will start displaying measured values. The three buttons allow the user to scroll through the available measurements.

ENERGY DISPLAYS



Press the  button to select Total kWh or kWh Count display pages. The kWh Count display remains visible for 1 minute before the unit reverts to Total kWh mode.

Press  and  together and hold for 5 seconds to reset the kWh Count register to zero. Scaling of the energy registers is set by the nominal input currents and voltages and remains constant during operation of the meter. Energy registers will accumulate from zero to 99,999,999 then restart from zero.

INSTANTANEOUS kW DISPLAY

Press  to select the following display:

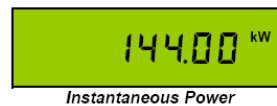



The instantaneous power display may show negative values indicating export power or incorrectly wired inputs. REV CT will also be show indicating that the most likely cause of the negative reading is one or more current transformers fitted the wrong way round on the primary conductor.

5 PROGRAMMING

CT SET-UP





The instrument must be set up for the CTs to which it is connected. This need only be done once, after which the setting is maintained in memory for the life of the unit regardless of whether it is powered up or not.

To enter programming mode press  and  simultaneously for 5 seconds. The unit shows the CT primary settings screen.





The CT primary value may then be set from the following nominal values (secondary value must be 5A):

5, 10, 15, 20, 30, 40, 50, 60, 80, 100, 150, 200, 250, 300, 400, 500, 600, 800, 1000, 1200, 1250, 1500, 1600, 2000, 2400, 3000, 2500, 4000, 4500, 5000, 5500, 6000, 6500, 7000, 7500, 8000, 8500, 9000, 9500, 10000, 10500, 11000, 11500, 12000, 12500, 13000, 13500, 14000, 14500, 15000, 15500, 16000, 16500, 17000, 17500, 18000, 18500, 19000, 19500, 2000, 205000, 21000, 21500, 22500, 23000, 23500, 24000, 24500, 25000

Press the  or  key until the desired current is displayed. If the desired CT value is not present in the above list, the ratio may be 'fine adjusted' as follows: Press and hold the  and  buttons simultaneously for 2 seconds to enter 'Fine Adjust Mode'. This is indicated by the display showing "CtF", this enables the CT primary value to be changed in 10A steps until the desired ratio is displayed. Press the  key to store the value and continue to the next parameter.

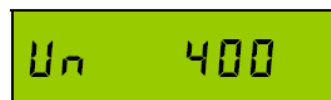
VT SET-UP



The default voltage setting is 400V and this value should not be altered. Press the  key to continue to the next parameter.

PULSE SET-UP



The pulse rate value (PLr) may be set between 0.1 and 100 pulses per unit. Press the ▲ or ▼ key until the desired pulse is displayed. Note that the unit of energy (Wh/kWh/MWh) will automatically change to reflect the primary values of CT & VT previously set. The pulse value is set for both outputs during the process. Press the ◀ key to store the value and move to the next parameter.



Using the ▲ or ▼ key the pulse duration value (PLt) may be set in increments between 100mS & 20 seconds as required. Press the ◀ key to store the value and move to the next parameter.

The Pulse Output Test (Pto) allows the meter pulse output and connected data collection hardware to be tested, regardless of whether an actual load is present. Press the ▲ button to start the test. The display will show "Ptr" and the output will pulse. This is verified by the front panel l.e.d.s. Press the ▲ and ▼ together to stop the test and reset the test counter.

SAVE & EXIT

After the unit has been set correctly, press the ◀ button to save the set values and exit. The display will show "storing" to confirm this action.

6 TECHNICAL CHARACTERISTICS

Connection: 3 Phase 3 or 4 wire Unbalanced, 3 Phase Balanced, Single Phase Load.

Inputs: Voltage: 400/230V 3 Phase 3/4 wire
Current: 5A – External CTs. Fully isolated.

Burden: <0.1VA per phase Current/Voltage

Pulse Output: Opto isolated volt free contact
Rating: 100mA ac/dc, 100V ac/dc max
Value: 1 pulse per kWh
1 pulse per 10 kWh
1 pulse per 100 kWh
1 pulse per 1000 kWh

Duration: 100ms.

Isolation: 2.5kV for 1 minute

Power Supply: 230V 50/60Hz +/- 15%

Overload: Voltage x 4 for 1 hour

Current x 40 for 0.5 seconds max

Consumption: 2VA

Weight: 325g

IP Rating: Instrument = IP20 Front panel = IP40

Temp Range: -10° - +65°

Dims: 106w x 58d x 90h mm (6 DIN)



NOTE: Do not expose the instrument display to direct sunlight.

ELCOMPONENT
Making sense of your energy

Unit 5 Southmill Trading Centre, Southmill Road, Bishop's Stortford, Herts. CM23 3DY.

01279 503173 sales@elcomponent.co.uk

www.elcomponent.co.uk

08.08